

EX38CT (RHFE-1005FTA2)

Type of Appliance	Direct vent wall furnace suitable for homes, apartments, and condominiums; modular/mobile home approved; forced combustion, forced convection	
Rinnai Model Number	RHFE-1005FTA2-N (Natural gas)	RHFE-1005FTA2-P (Propane)
Gas Rate Input (BTU/hour)	Low - 13,200 High - 38,400	Low - 13,200 High - 36,500
Gas Rate Output (BTU/hour)	Low - 10,560 High - 30,720	Low - 10,560 High - 29,200
AFUE Rating	80%	
Minimum Gas Supply Pressure	3.5 in (89 mm) W.C.	8 in (203 mm) W.C.
Maximum Gas Supply Pressure	10.5 in (267 mm) W.C	13 in (330 mm) W.C.
Electrical Connection	AC 120V, 60 Hz, 117 watts	
Gas Connection	1/2 inch FNPT	
Combustion System	Stainless Steel Bunsen Burners	
Ignition System	Electronic spark ignition	
Temperature Settings	Low (LO): minimum combustion 60° - 80° F in 1° increments High (HI): maximum combustion	
Temperature Control	<ul style="list-style-type: none"> • Electronic thermostat • Temperature limiting program to comply with Inside Design Temperature limits 	
Humidifier Tray	Enameled tray with capacity of 6.3 pints (3 liters)	
Weight	Approximately 88 lbs (40 kg)	
Clearance from Combustibles	Side: 2 inches (50 mm) Front: 40 inches (1 m)	Top: 10 inches (250 mm)
Noise Level	39 - 46 dB(A)	
Warm Air Outlet	Bottom front louvers	

FEATURES

Timer Settings	Starts and turns off the heater at two timer settings
Seven-stage modulating gas valve	provides precise gas flow by operating from one to seven stages
Negative coefficient thermistor	detects temperature change in 1/2 of a degree
Variable speed inducer motor with pressure switch	monitors and controls combustion fan and allows the appliance to overcome winds of up to 40 mph
Quiet operation	reduces noise through use of swept blades in convection fan; and through the design of the combustion chamber and heat exchanger which silently
Self diagnostic electronic	continually monitors functions; provides auto shutdown codes; indicates
Wall Thermostat connectable	Ability to connect to a field supplied wall thermostat

Safety Devices

- Flame rod detects flame failure; results in auto shutdown to prevent escape of gas
- Thermal fuse, and thermistor detect overheat condition; results in auto shutdown
- 5 amp fuse protects against power surge; results in auto shutdown
- Abnormal spark at time of ignition results in auto shutdown
- Combustion fan purges any gas from the combustion chamber before ignition
- Convection fan continues to run after burner shutdown to cool internal parts
- Function lock prevents inadvertent operation
- Appliance shuts down if room reaches 104° F (40° C)

Venting

Concentric; 3 1/8 inch (80 mm) wall hole

Maximum Vent Length

13 feet (4 m) with a maximum of 2 bends

Wall Thickness and Flue Manifold Kits

(the "A" vent kit is included with the appliance)

Name	Kit No.	Fits Walls
S Vent Kit	FOT-150	3 - 4 1/2 in (75 - 115 mm)
A Vent Kit	FOT-151	4 1/2 - 9 1/2 in (115 - 240 mm)
B Vent Kit	FOT-152	9 1/2 - 15 3/4 in (240 - 400mm)
C Vent Kit	FOT-153	15 3/4 - 23 5/8 in (400 - 600 mm)
D Vent Kit	FOT-154	23 5/8 - 31 1/2 in (600 - 800 mm)

Wall Thermostat Kit

204000045 (US); 204000048 Canada

Warranty

Labor: 2 years; Parts: 5 years; Heat Exchanger: 10 years

Rinnai is continually updating and improving products; therefore, specifications are subject to change without prior notice. Local, state, provincial and federal codes must be adhered to prior to installation.

DIMENSIONS

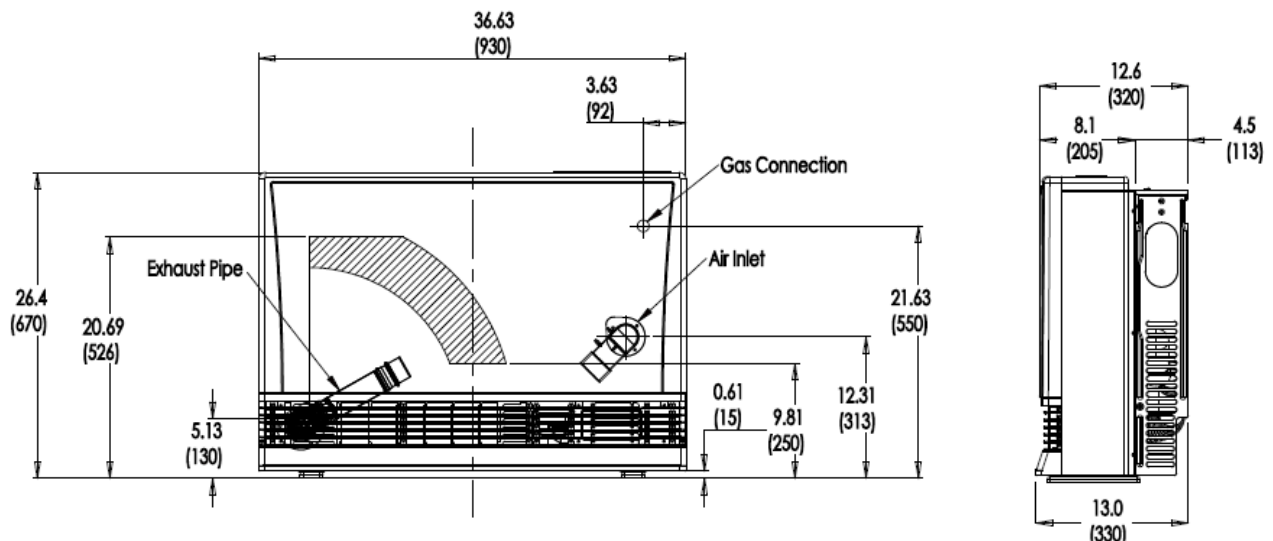

EX38CT (RHFE-1005FTA2)

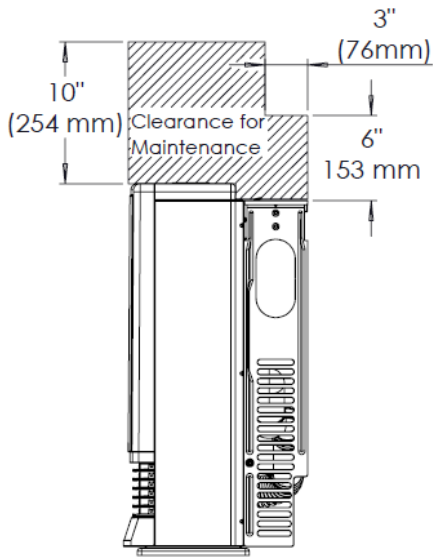

Clearance for Maintenance

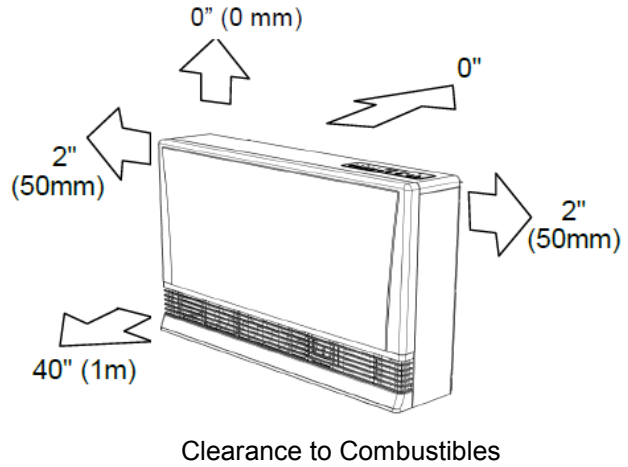

Clearance to Combustibles

International Energy Conservation Code (IECC) Climate Regions

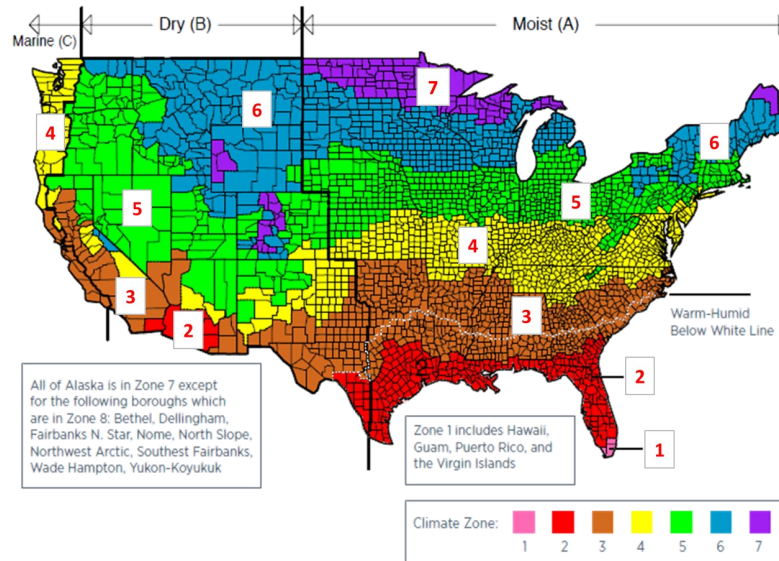

Zone	Cubic Feet	Square Feet*
1	14,511 - 25,600	1,811 - 3,200
2	9,411 - 16,610	1181 - 2,080
3	7,921 - 13,960	991 - 1,750
4	6,701 - 11,820	841 - 1,480
5	5,531 - 9,750	691 - 1,220
6	4,521 - 7,980	571 - 1,000
7	4,131 - 7,280	521 - 910

- Selection is based on installation locations at 2000ft or below. If the installation is above 2000ft please contact Rinnai.
- In bathrooms, select a product equal to or less than 6000BTUH.
- In bedrooms, select a product equal to or less than 10000BTUH.
- In single rooms in Region V, multiply the room's volume by 3.20. The result is the maximum heat input (BTUH) of the product you should consider.
- Chart should not be used as the sole document for making final product selection. Consult with your Rinnai independent dealer.
- Square footage column based off of an 8ft ceiling assumption.
- The guidelines apply to average house construction.
- This is intended to be used as a guide and not a replacement for a professionally engineered project.
- Rinnai has not been to the location so this guidance is for your assistance only and should not be the sole factor in making a sizing selection.
- Sizing does not describe a complete system.
- The contractor/engineer must determine the necessary components for and configuration of the particular system being installed.
- Sizing does not imply compliance with local building codes.
- It is the responsibility of the engineer/contractor to ensure the installation is in accordance with all local building codes.
- Confer with local building officials before installation.
- RAC, its agents, employees, directors, officers, parent or affiliate companies assume no liability for damages arising from information provided herein to or by consumers or third parties or for damages arising from or associated with water quality, compliance with local codes, installation methods, materials or other circumstances related to application or installation.
- For primary heat applications, perform a Manual J sizing calculation.
- Chart is to be used for supplemental heat applications only.